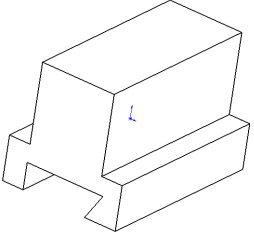
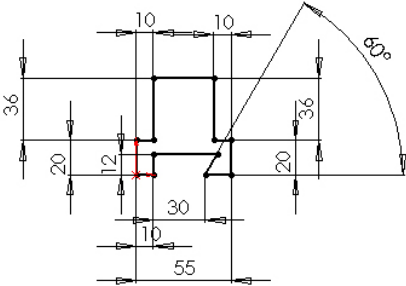
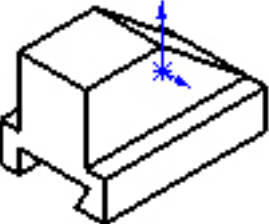
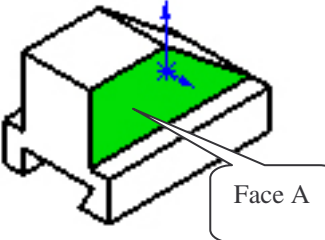
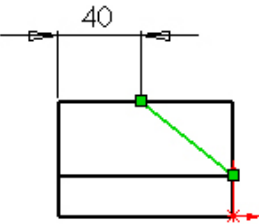
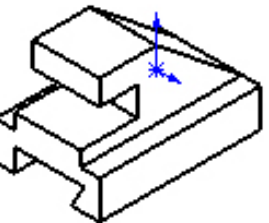
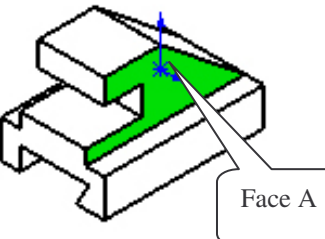
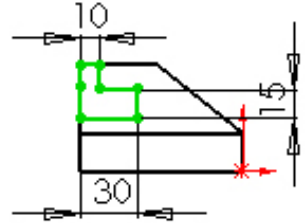
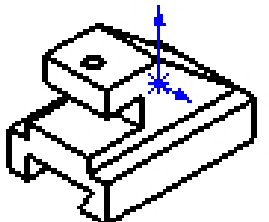
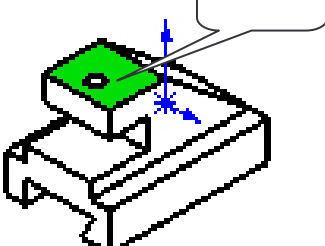
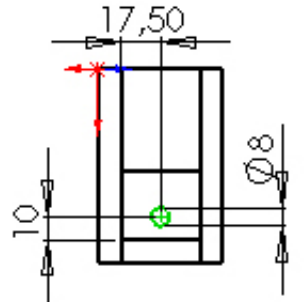

TABLEAU DE DECOMPOSITION VOLUMIQUE DU PORTE-OUTIL

Nom du volume	Dessin du volume en perspective	Plan, face ou arête à sélectionner	Esquisse cotée	Fonction utilisée
Vol. 1		Plan de face		Extrusion profondeur 42mm
Vol. 2				Extrusion profondeur : A travers tout
Vol. 3				Extrusion profondeur : A travers tout
Vol. 4				Extrusion avec enlèvement de matière « à travers tout »